



## TOSAERBA SARP

### SLM-5360HX 2-2

Da matricola 6210001 gennaio 2008

## ESPLOSO RICAMBI

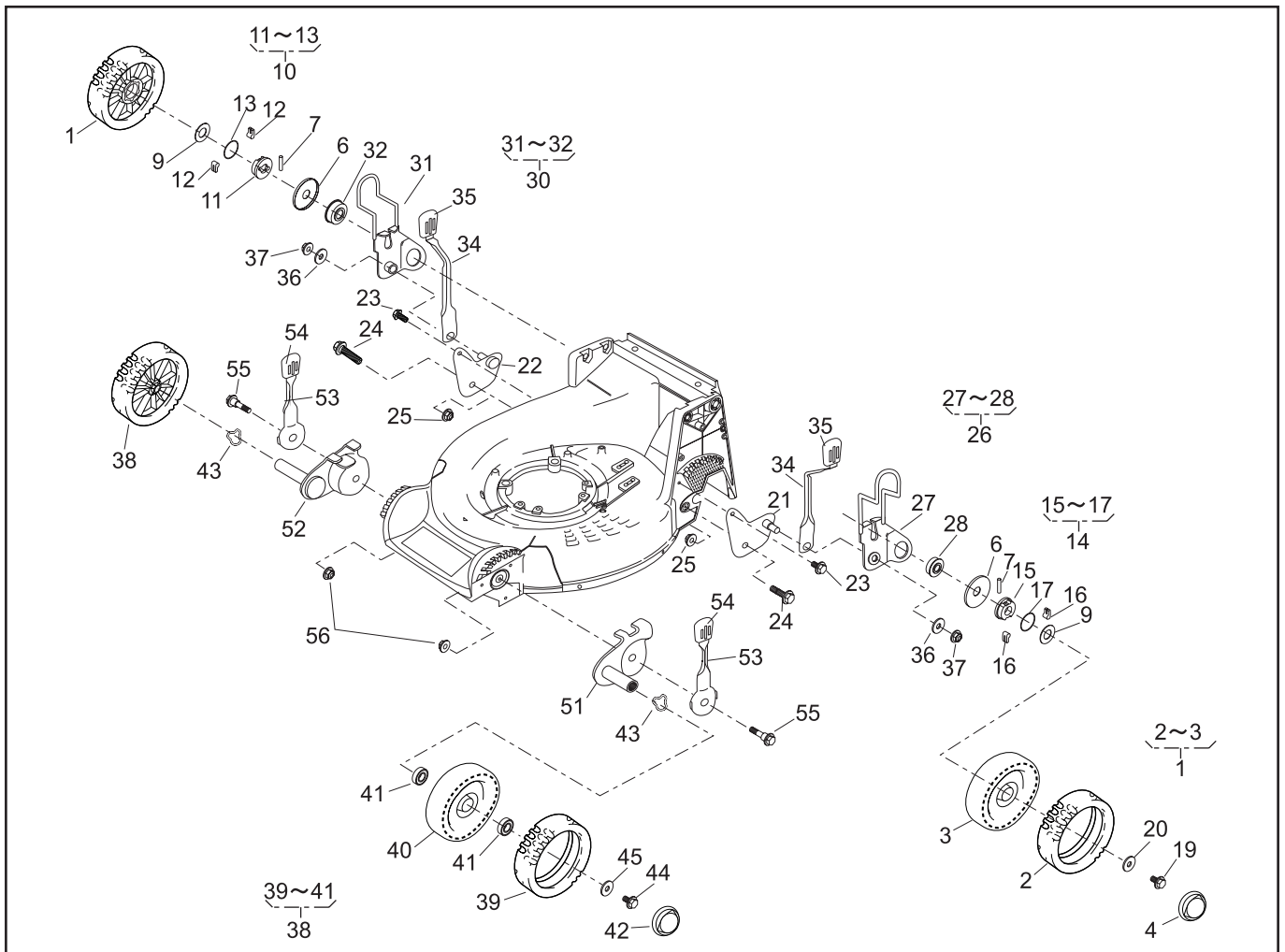

## PARTS LIST

P/L No. 46014-501-00

NOTE

REF. No.	PARTS No.	PARTS NAME	WHEEL			1/2		Dec. 25, 2006	
			Q'TY INCLUDING	PRICE( )	RECOMM.(%) Lot.100	REMARKS			
1	71041   112	WHEEL ASSY(R)	2						
2	91086   106	TIRE	2						
3	36107   101	WHEEL	2						
4	36070   110	CAP	2						
5									
6	61003   112	THRUST PLATE	2						
7	31034   137	PIN	2						
8									
9	68036   146	WASHER	2						
10	71158   101	RATCHET ASSY(R)	1						
11	11102   138	HOLDER	1						
12	31034   170	PIN	2						
13	68013   266	SPRING	1						
14	71158   102	RATCHET ASSY(L)	1						
15	11102   138	HOLDER	1						
16	31034   170	PIN	2						
17	68013   266	SPRING	1						
18									
19	31057   181	HEXAGON BOLT	2						
20	68036   101	WASHER	2						
21	11006   151	STAY C.P.(RL)	1						
22	11006   152	STAY C.P.(RR)	1						
23	342L   0612	FLANGE TAPPING BOLT	2						
24	31057   255	HEXAGON BOLT	2						
25	584L   0800	U-FLANGE NUT	2						
26	71122   112	ADJUSTER ASSY(L)	1						
27	11142   131	ADJUSTER(RL)	1						
28	945L   0349	BEARING	1						
29									
30	71122   113	ADJUSTER ASSY(R)	1						



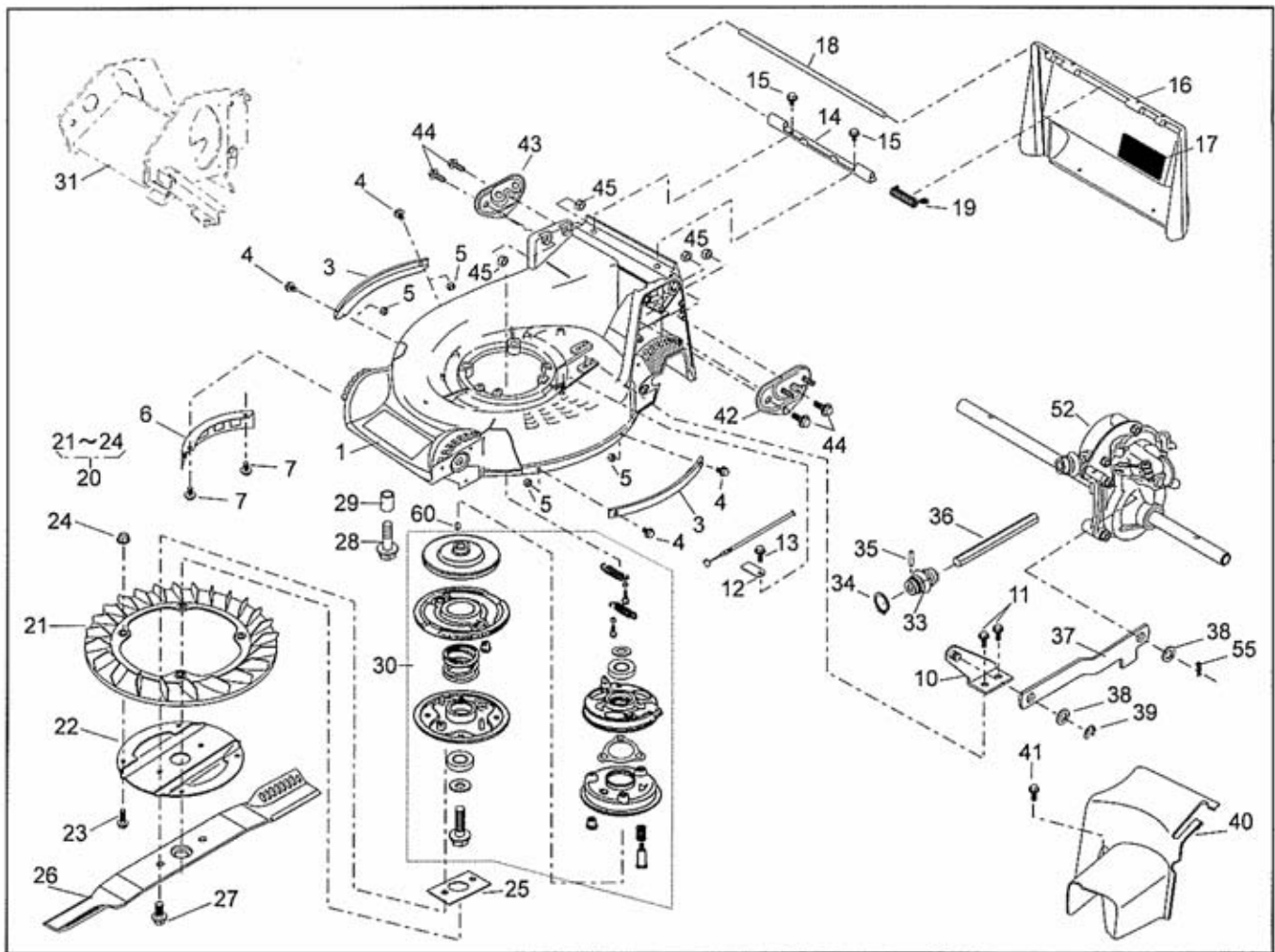

## PARTS LIST

P/L No. 46014-536-01

NOTE

REF. No.	PARTS No.		PARTS NAME	GRASS-CUTTING		1/2	REMARKS
				Q'TY INCLUDING	PRICE( )	RECOMM.(%) Lot.100	
1	51043	151 42	HOUSING	1			
2							
3	51090	117 09	PROTECTOR	2			
4	335L	0616	FLANGE BOLT	4			
5	512L	0600	HEXAGON NUT	4			
6	36065	180	COVER	1			
7	342L	0612	FLANGE TAPPING BOLT	2			
8							
9							
10	11006	155	STAY C.P.	1			
11	342L	0612	FLANGE TAPPING BOLT	2			
12	11113	407	STAY	1			
13	342L	0612	FLANGE TAPPING BOLT	1			
14	11113	292	STAY	1			
15	342L	0612	FLANGE TAPPING BOLT	2			
16	36068	196 46	GUARD	1			
17	36080	149	RUBBER SHEET	1			
18	64014	324	SHAFT	1			
19	68013	336	SPRING	1			
20	71082	111	FAN ASS'Y	1			
21	51125	103	FAN	1			
22	11102	151	HOLDER	1			
23	31062	169	PRE-COAT LOCK BOLT	4			
24	579L	0600	FLANGE NUT	4			
25	61024	208	SPACER	1			
26	91014	188	BLADE	1			
27	31057	197	HEXAGON BOLT	2			
28	31057	243	HEXAGON BOLT	4			
29	61024	142	SPACER	3			
30	71067	106	BRAKE ASS'Y	1			

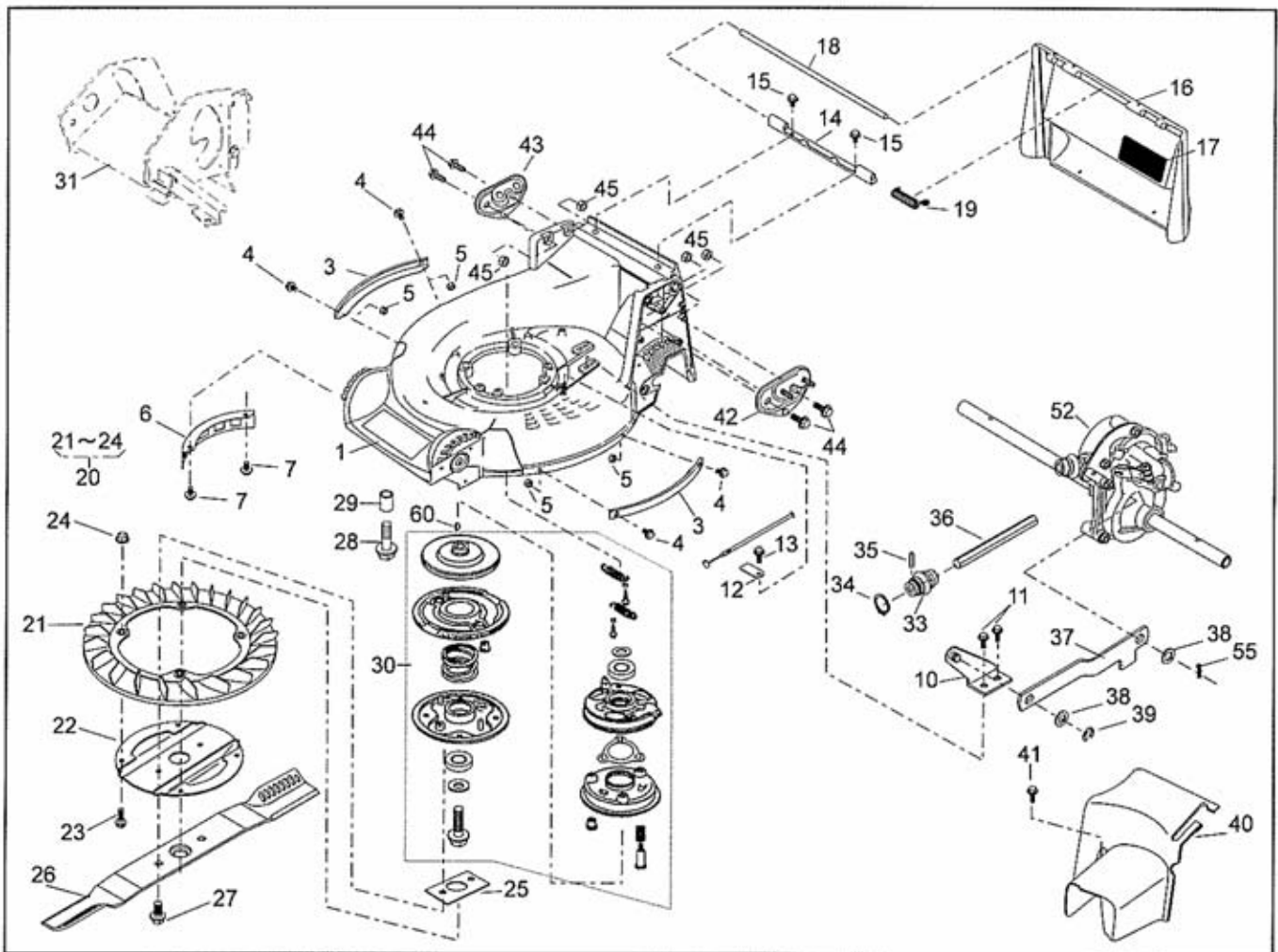

## PARTS LIST

P/L No. 46014-536-01

NOTE  
B

REF. No.	PARTS No.	PARTS NAME	GRASS-CUTTING		2/2	RECOMM.(%) Lot.100	Dec. 25, 2006	REMARKS
			Q'TY	PRICE( )				
31		COVER UNIT (Ref. P/L No. 46012-550-**)						
32								
33	91097 101	UNIVERSAL JOINT	1					
34	812V 2000	C-SNAP RING	1					
35	717B 0418	PARALLEL PIN	1					
36	64014 358	SHAFT	1					
37	91049 135	CONNECTOR	1					
38	68036 280	WASHER	2					
39	816V 0800	E-SNAP RING	1					
40	36065 438	COVER	1					
41	342L 0616	FLANGE TAPPING BOLT	1					
42	51116 149	HANDLE BRACKET(L)	1					
43	51116 150	HANDLE BRACKET(R)	1					
44	31057 255	HEXAGON BOLT	4					
45	512L 0800	HEXAGON NUT	4					
46								
47								
48								
49								
50								
51								
52	71008 275	GEAR CASE ASS'Y	1					
53								
54								
55	733L 1000	SNAP PIN	1					
56								
57								
58								
59	122039	ENGINE:HONDA GXV160H2-SFL1-R280	1					
60		WOODRUFF KEY	1					

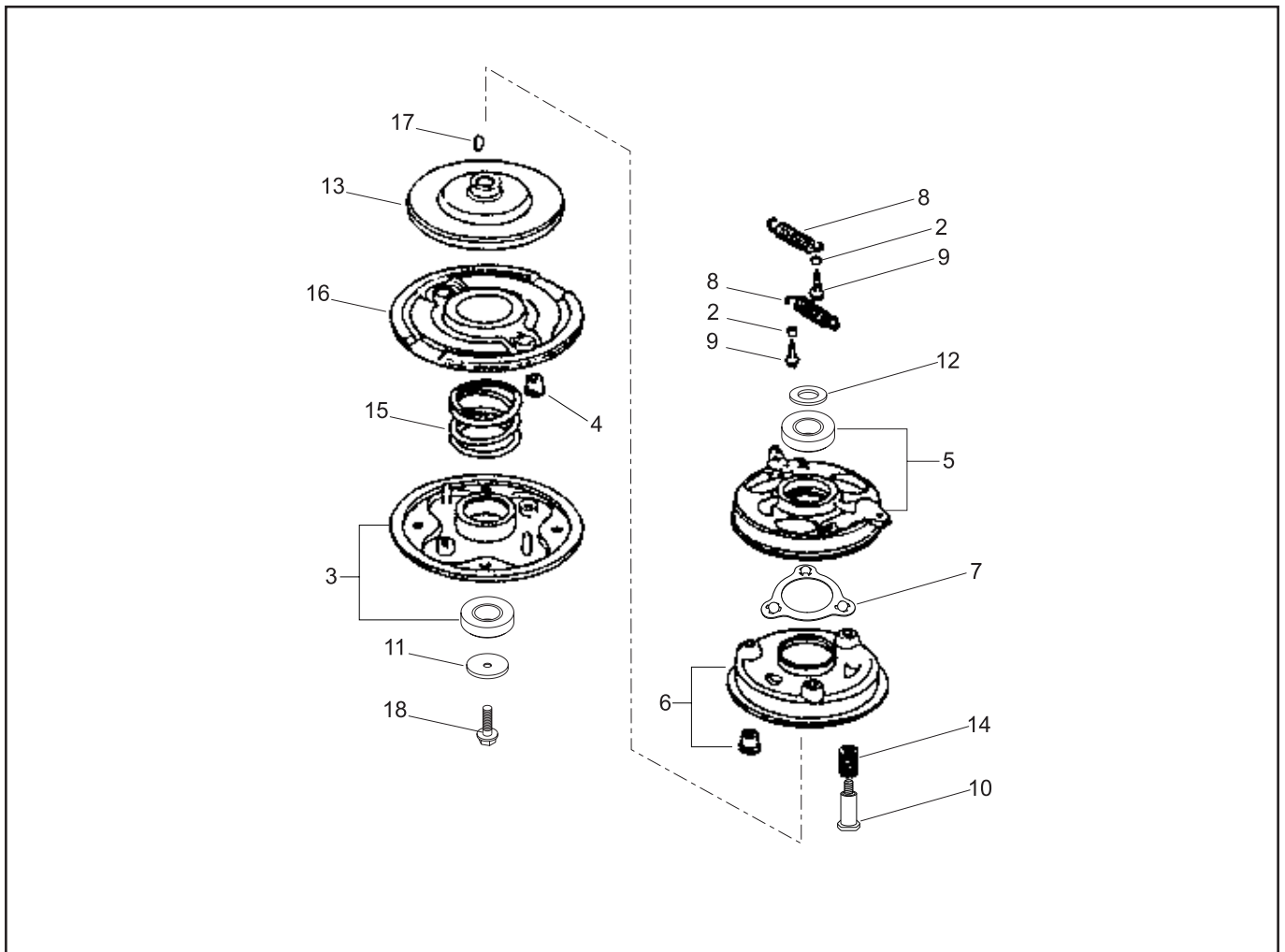

## PARTS LIST

### BRAKE ASSY (71067-106)

P/L No. 46014-266-02

REF. No.	PARTS No.	PARTS NAME	BBC			1/1	Feb.09,2005
			Q'TY INCLUDING	PRICE( )	RECOMM.(%) Lot.100	REMARKS	
1	71067 106	BRAKE ASSY	1				
2	19512 883 000	FAN COLLAR	2				
3	72600 VA4 010	HOLDER ASSY	1				
4	72613 VA4 000	BUSH, BLADE HOLDER	2				
5	75090 VA4 030	CONTROL ASSY	1				
6	75100 VA4 010	BRAKE C.P.	1				
7	75110 VA4 000	BALL RETAINER C.P.	1				
8	75182 VA3 J00	SPRING, CLUTCH RETURN	2				
9	90014 952 000	FLANGE BOLT	2				6 x 14
10	90021 VA4 000	BOLT, SPECIAL	3				6 mm
11	90409 952 000	WASHER	1				10 mm
12	90501 952 010	THRUST WASHER	1				
13	75130 VA4 000	BRAKE DISK	1				
14	75132 VA4 000	SPRING, BRAKE HOLDER	3				
15	75183 VA3 J00	SPRING, CLUTCH	1				
16	75150 VA3 J01	DRIVEN DISK C.P.	1				
17	94401 16150	WOODRUFF KEY	1				
18	90105 960 003	BOLT (10x25)	1				
19							
20							
21							
22							
23							
24							
25							
26							
27							
28							

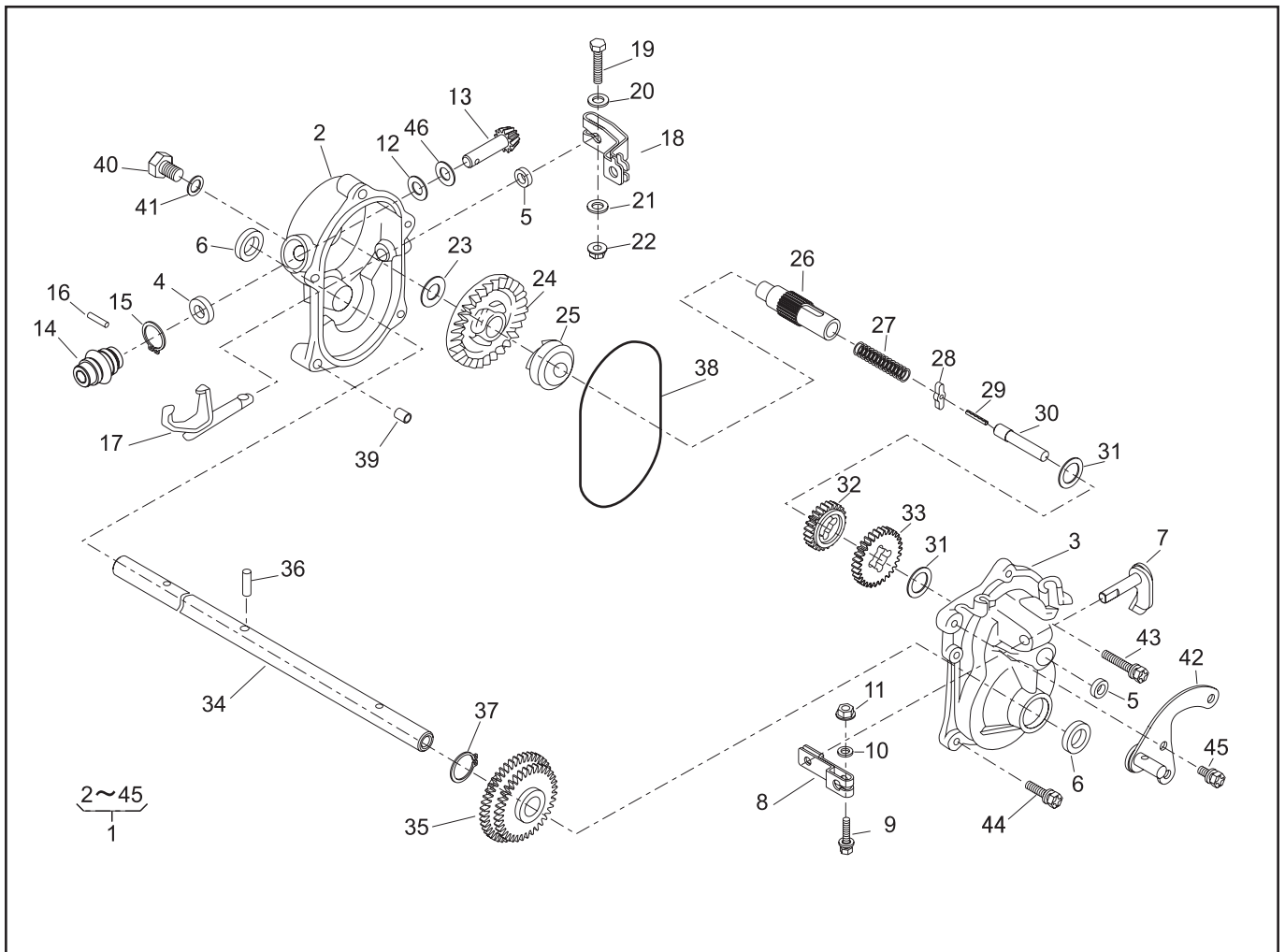

## PARTS LIST

### GEAR CASE ASSY (71008-275)

P/L No. 46014-262-04

REF. No.	PARTS No.	PARTS NAME	GEAR CASE			1/2		Dec. 25, 2006
			Q'TY INCLUDING	PRICE( )	RECOMM.(%) Lot.100	REMARKS		
1	71008   275	GEAR CASE ASS'Y	1			-		
2	51001   195	GEAR CASE	1			3		
3	51001   196	GEAR CASE	1			3		
4	61002   161	OIL SEAL	1			5	SD 10 20 5	
5	61002   162	OIL SEAL	2			5	SD 08 14 4	
6	61002   163	OIL SEAL	2			5	SD 15 24 5	
7	64024   104	SHIFTER SHAFT	1			3		
8	11104   119	ARM	1			3		
9	320L   0525	(+)HEXAGON BOLT (W/PW)	1			3	M5 × 25	
10	611L   0500	PLAIN WASHER	1			3	M5	
11	571L   0500	FLANGE NUT	1			3	M5	
12	61003   109	THRUST PLATE	1			5		
13	78003   130	PINION	1			3		
14	91097   101	UNIVERSAL JOINT	1			3		
15	812V   2000	C-SNAP RING		1		1	φ 20	
16	717B   0418	PARALLEL PIN		1		3	φ 4 × 18	
17	11097   106	SHIFTER FORK	1			3		
18	11104   137	ARM	1			3		
19	311M   0630	HEXAGON BOLT	1			3	M6 × 30	
20	611L   0600	PLAIN WASHER	1			3	M6	
21	613L   0600	PLAIN WASHER	1			3	M6	
22	571L   0600	FLANGE NUT	1			3	M6	
23	61024   117	SPACER	1			5		
24	78001   162	BEVEL GEAR	1			3		
25	11129   107	CLUTCH	1			3		
26	64014   236	SHAFT	1			3		
27	68013   262	SPRING	1			3		









